

BASIC INFORMATION ABOUT THE PRODUCT



- Modern, compact goat-type design, ideal as an additional source of heat and decoration.
- Possibility of installation in open spaces and wall recesses.
- High wood burning efficiency, offering profitability and eco-friendliness.
- Covered with high-temperature paint for protection and aesthetics.
- Air curtain at the windscreen and secondary air vents on the rear wall.
- Three-stage aeration and two dampers to regulate the air supply.
- Movable cast iron grate with ash pan for easy ash removal.
- External cold air intake for compatibility with mechanical ventilation.
- Decorated DECOR fireplace ceramics and polished fireplace glass with an air curtain resistant to 800°C.

Nominal power [kW]	6,5
Heating load range [kW]	3-8,5
Thermal efficiency [%]	83
CO emissions (at 13% O2) [g/m3]	0,038
Pollen emission [g/m3]	1,080
Average fuel consumption [kg/h]	1,9
Glass dimensions [mm]	390x540
Flue diameter [mm]	150
Inlet diameter [mm]	100
Weight [kg]	84
Efficiency factor	111,4



**LYNXS**

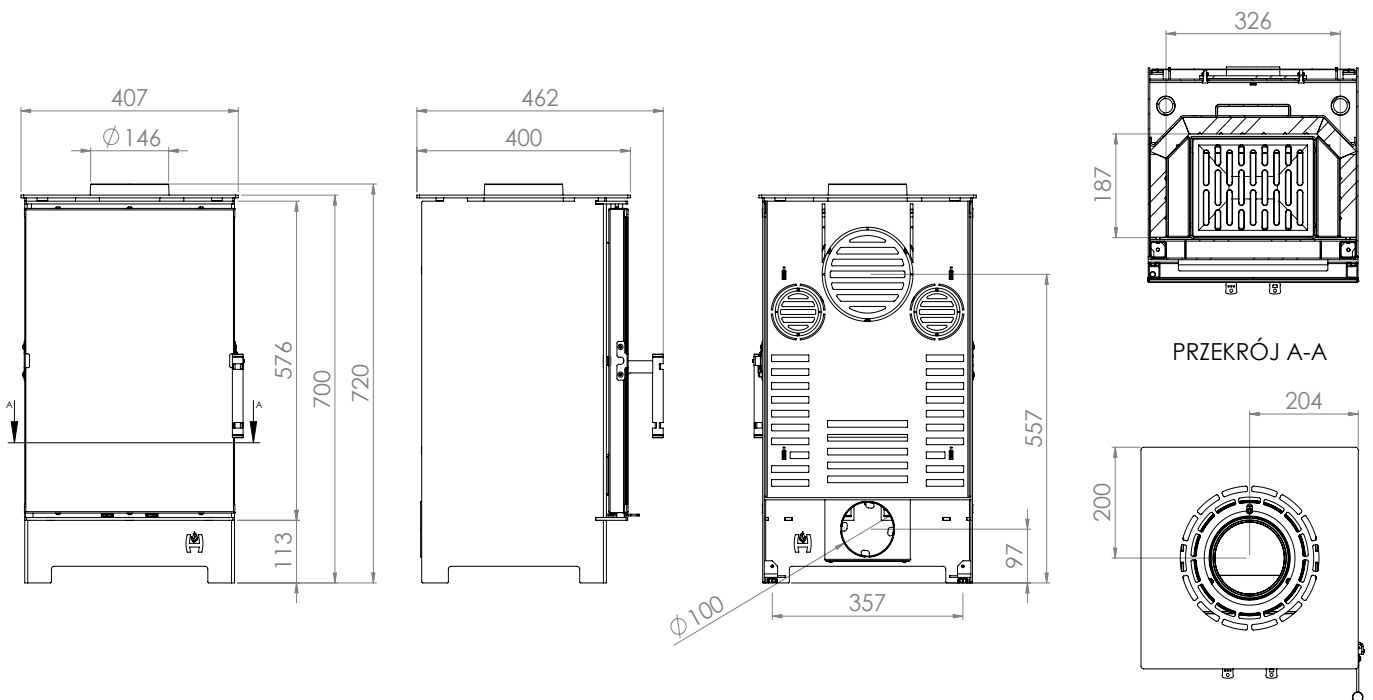

# LYNX